

Radbahn Berlin Transforming the City

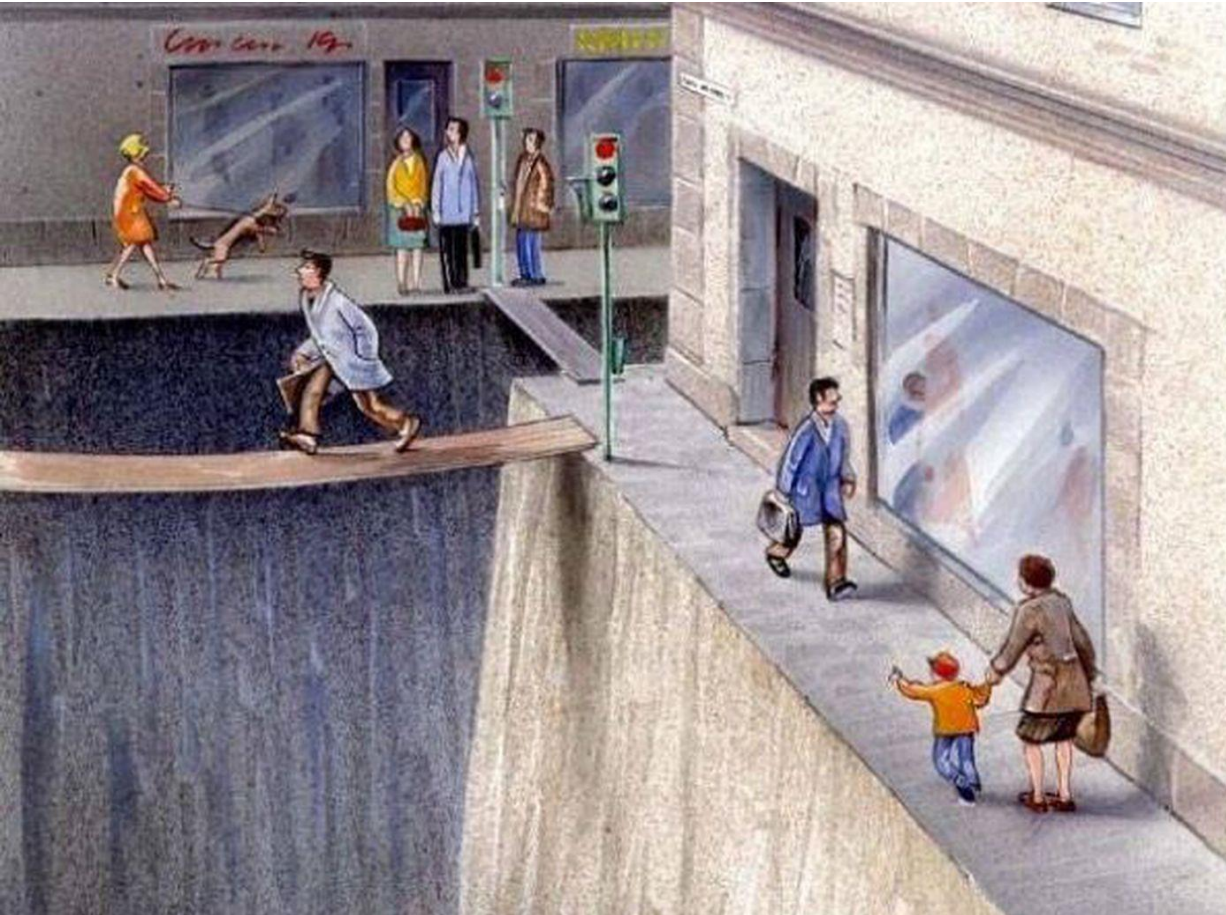

Radbahn Berlin

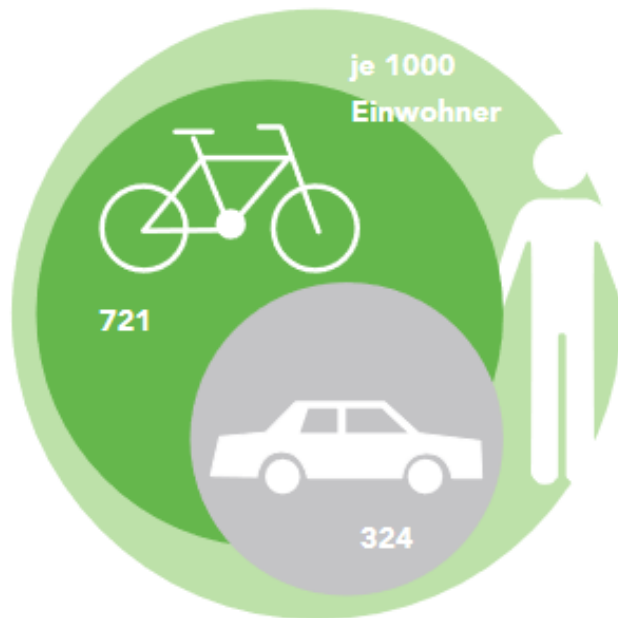

Mobility grade in Berlin
721 bicycles/1,000 inhabitants

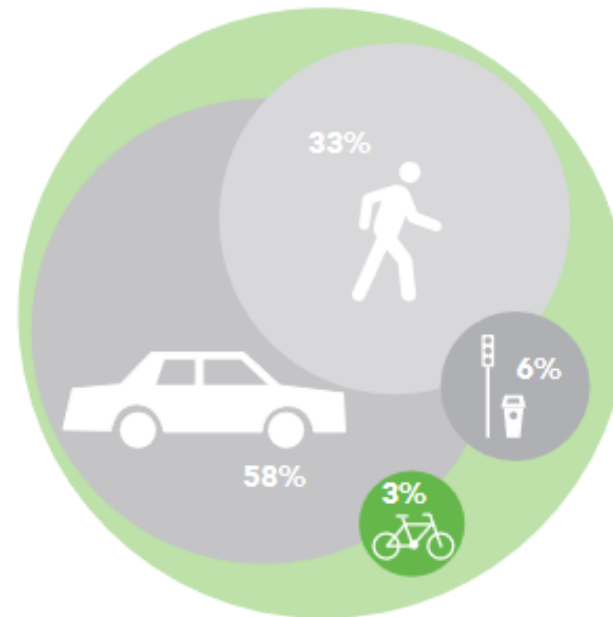

Transport surface area
3% bicycle road surface share

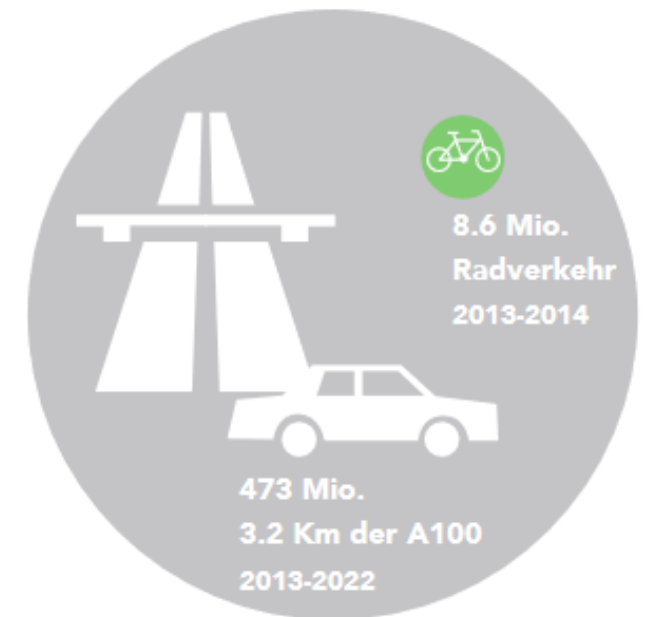

Infrastructure spending
8.6 Mio. EURO 2013-2014

Radbahn Berlin



Berlin Subway Line 1 today

Radbahn Berlin

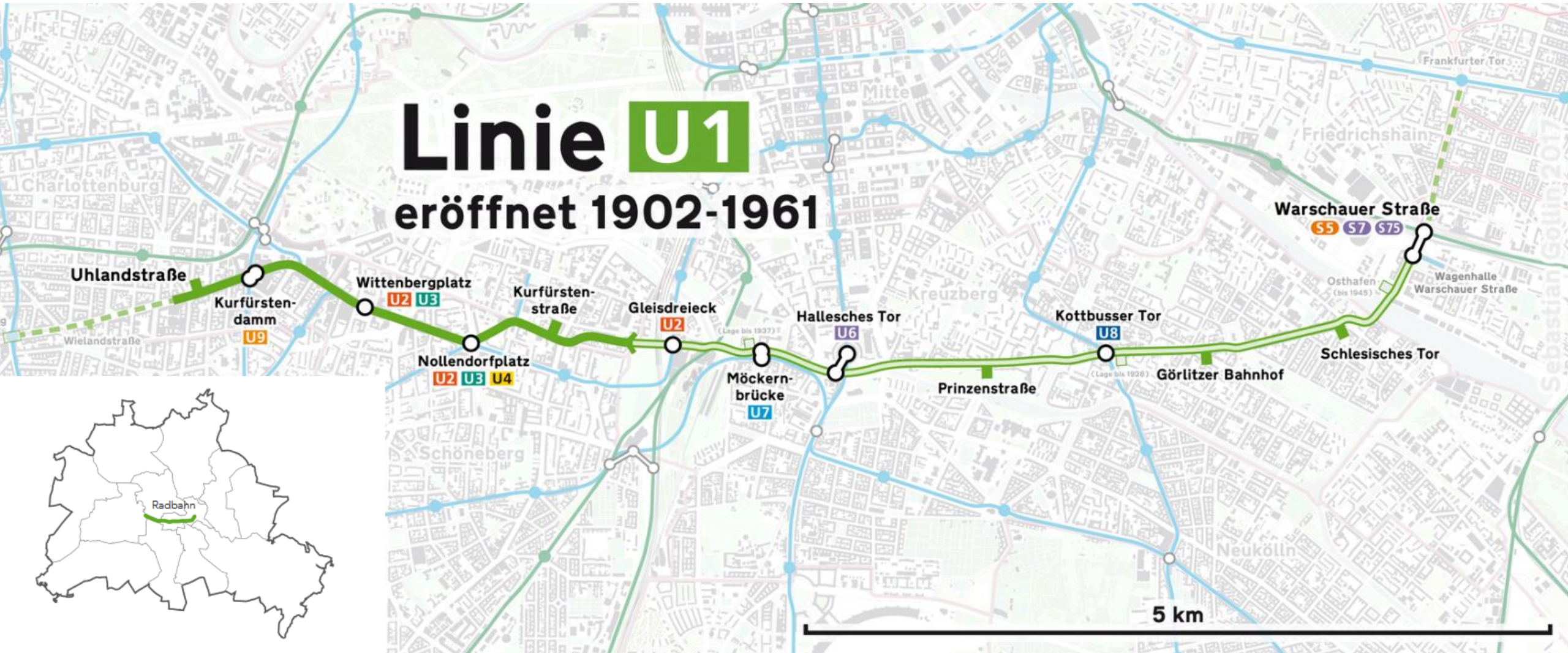

Radbahn Berlin

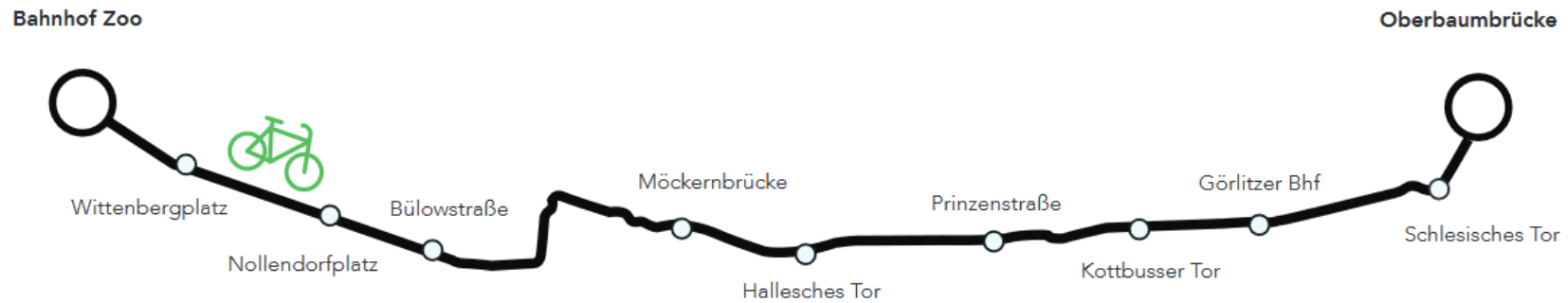

Radbahn Berlin

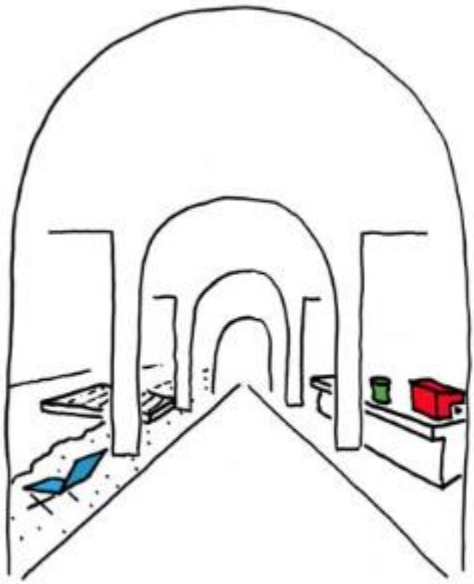

Silence & Recreation



Cycling Services

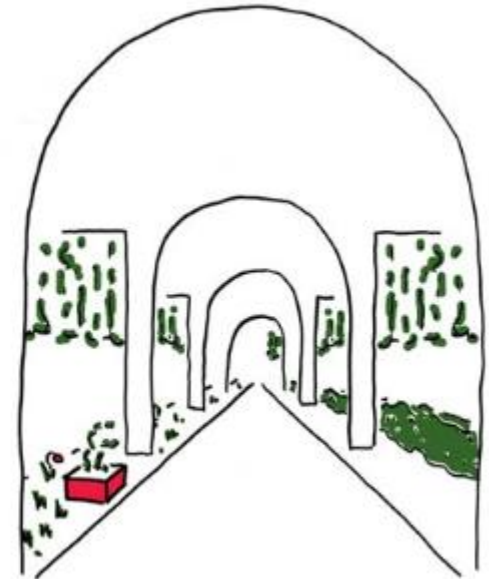

Gardens & Urban Nature

Radbahn Berlin - Urban Stimulation

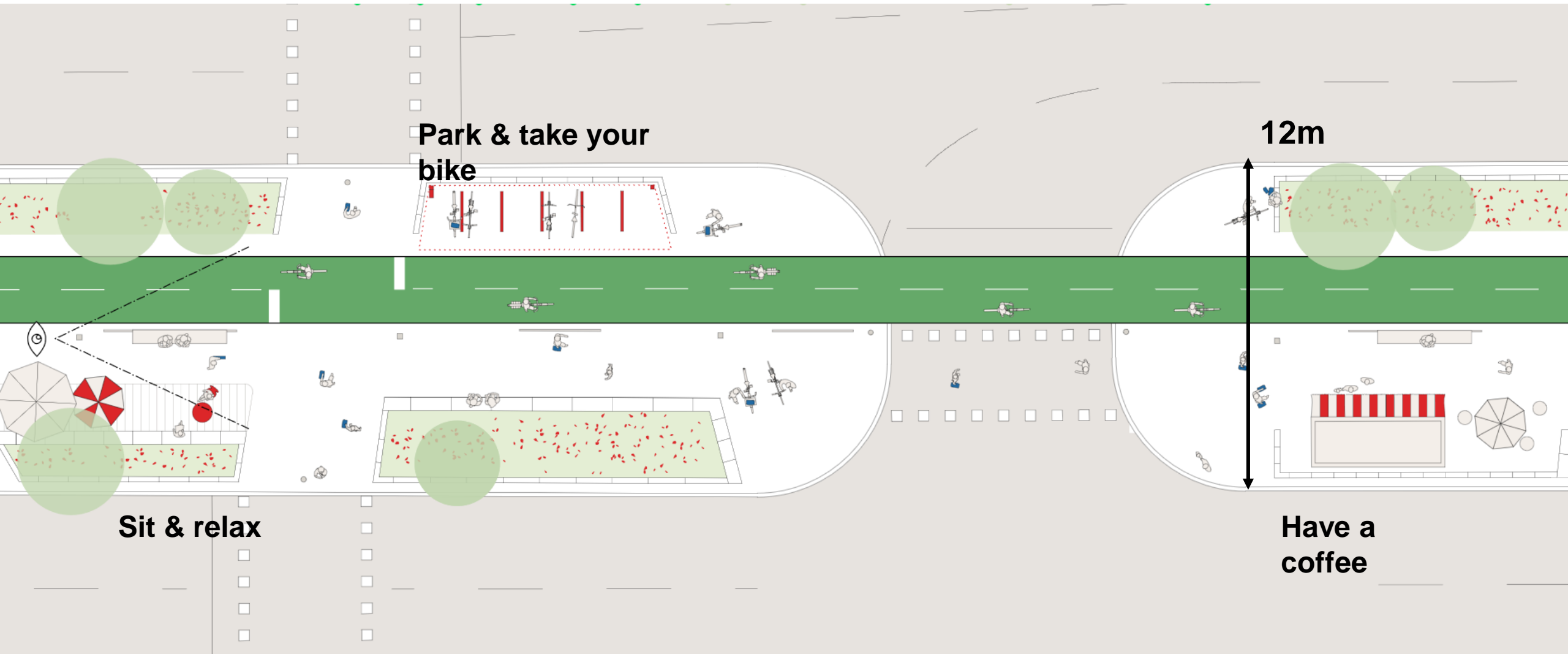

Radbahn Berlin – Mobility Hubs

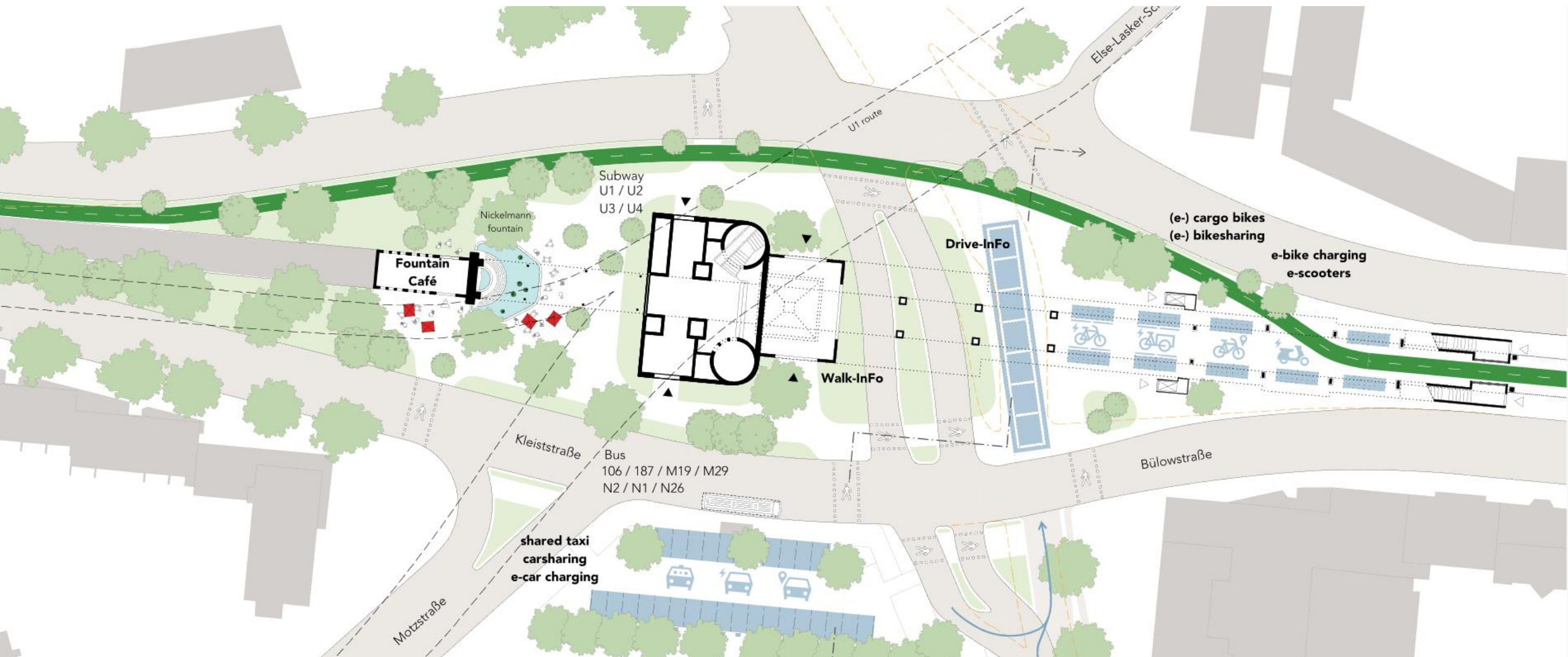

Radbahn Berlin – Spatial Quality

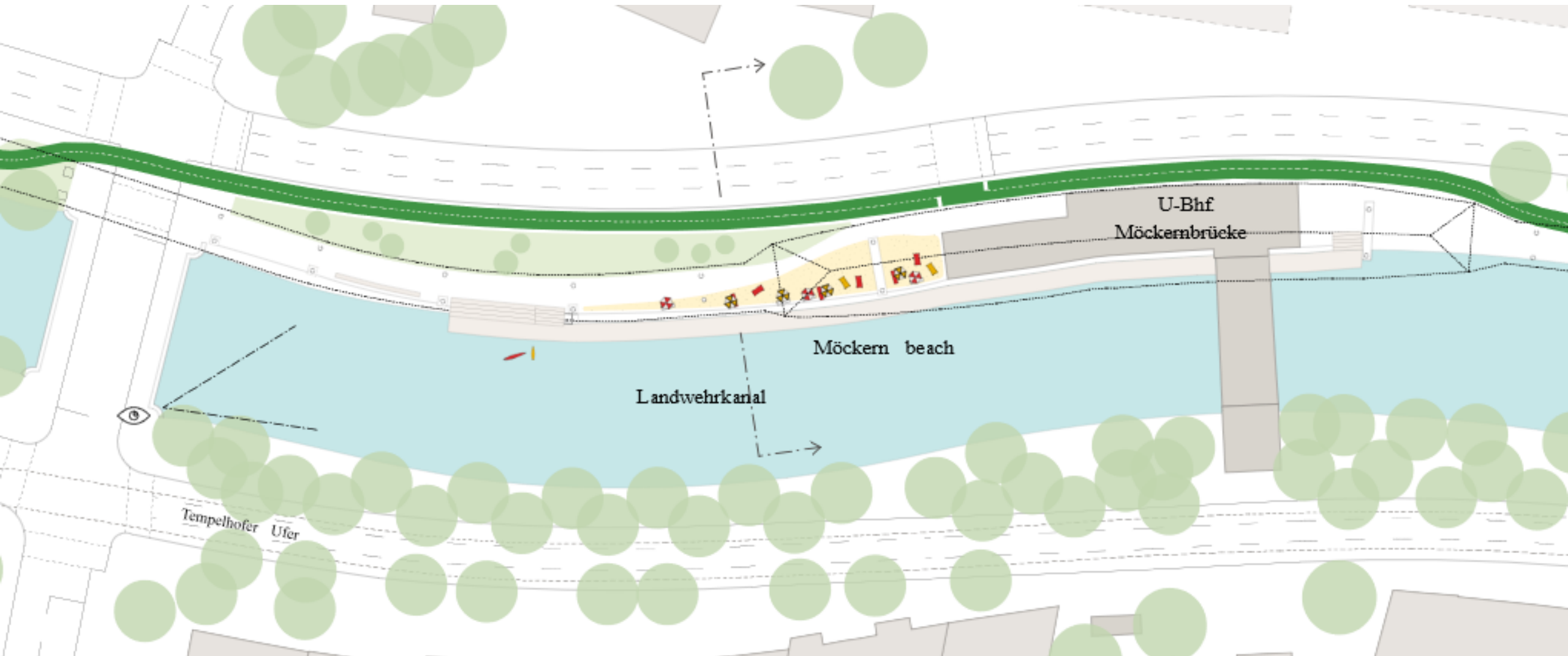

Radbahn Berlin

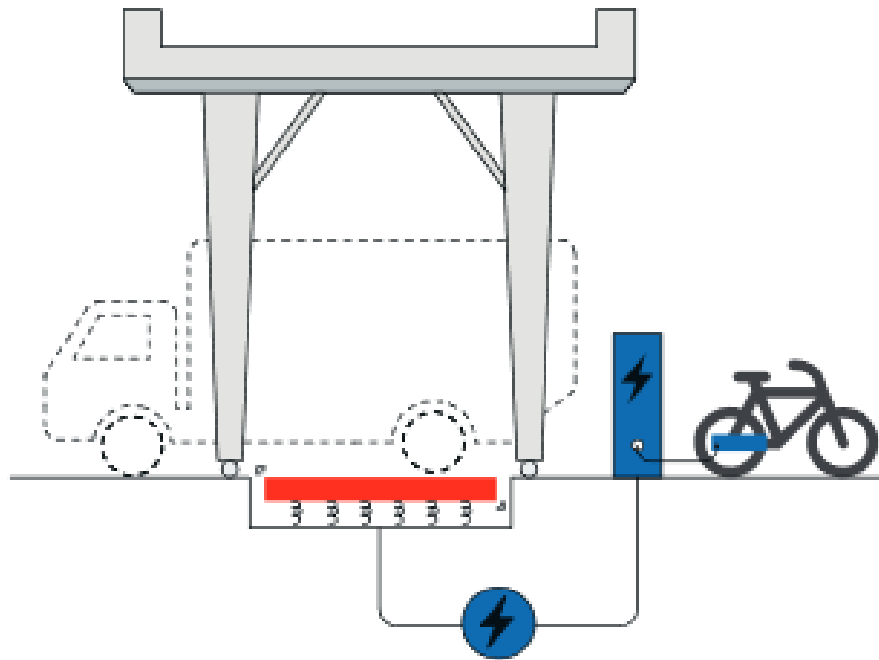

Kinetik

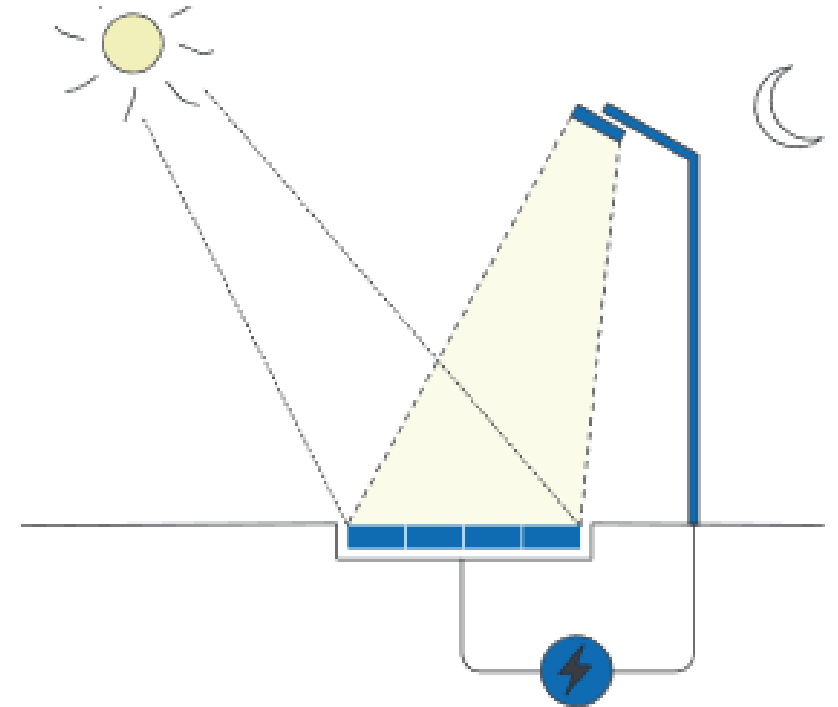

Solar

Radbahn Berlin



Thank you for your attention!

***“If we plan cities for cars and traffic, you get cars and traffic.
If we plan for people and places, we get people and places.” (Fred Kent)***

*Sebastian Ibold
Project Manager Sino-German
Cooperation on Low Carbon Transport
CLCT, GIZ China*

sebastian.ibold@giz.de
www.sustainabletransport.org

